

CO2 Rail Car Drawing Page 1

Step A.

Draw a LIGHT rectangle around the center of your paper.
Use the overall size of 14.6 by 6.2

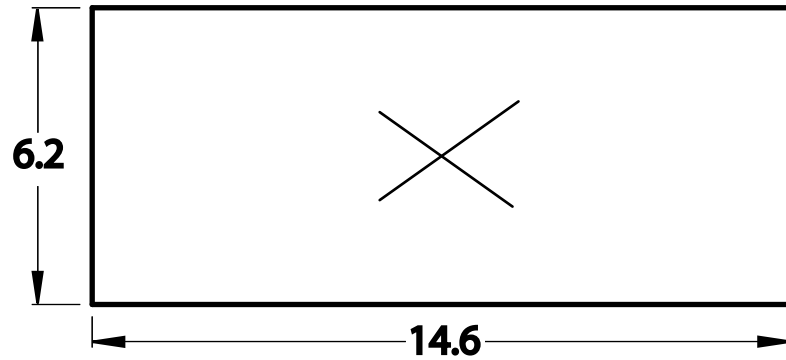

Step B.

Divide the rectangle into three views.
Erase lines between views.

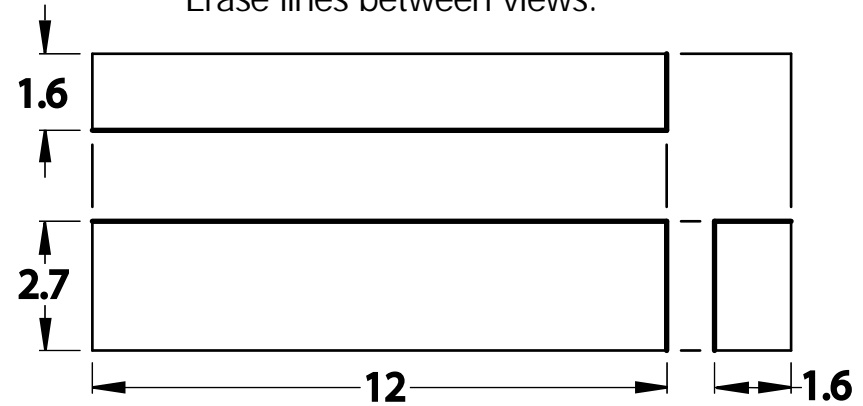

Step C.

Draw line for blank in side view.

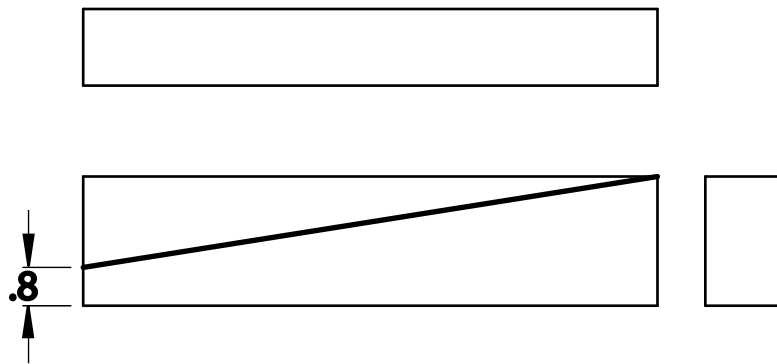

Step D.

Draw centerlines to locate
cartridge hole. Erase lines.

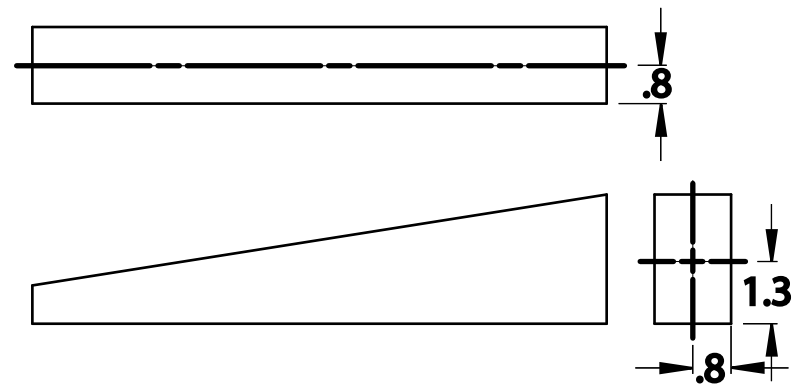

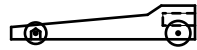

CO2 Rail Car Drawing Page 2

D2

Step E.

First, draw cartridge hole .812 diameter in back view. Use circle template to draw circle. Then, use T-square to transfer to side view. Use Triangle to transfer to top view.

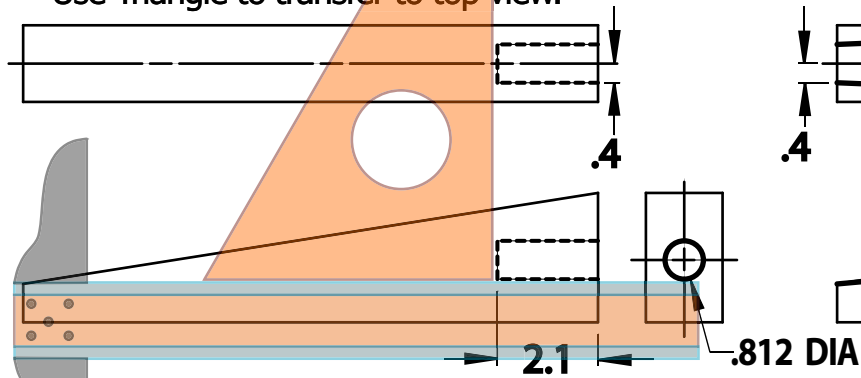

Step F.

Draw the details for the body. Make all the measure first, then draw the lines.

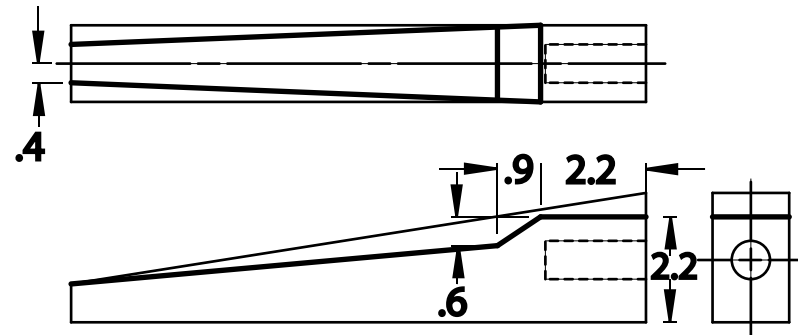

Step G.

Draw centerlines to locate wheels and axles.

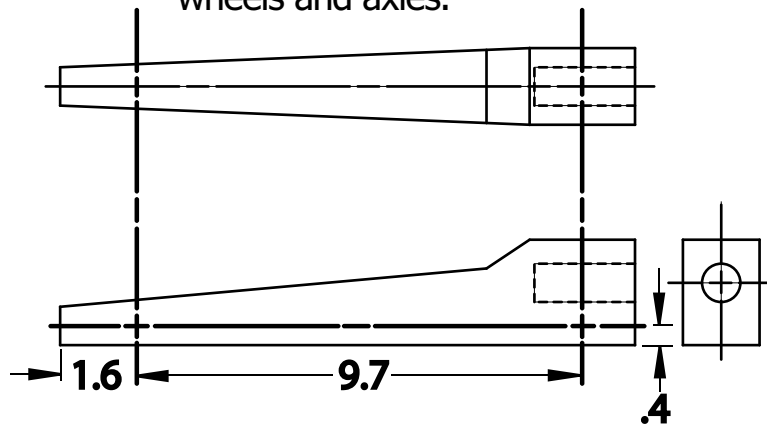

Step H.

Draw the front wheel supports.

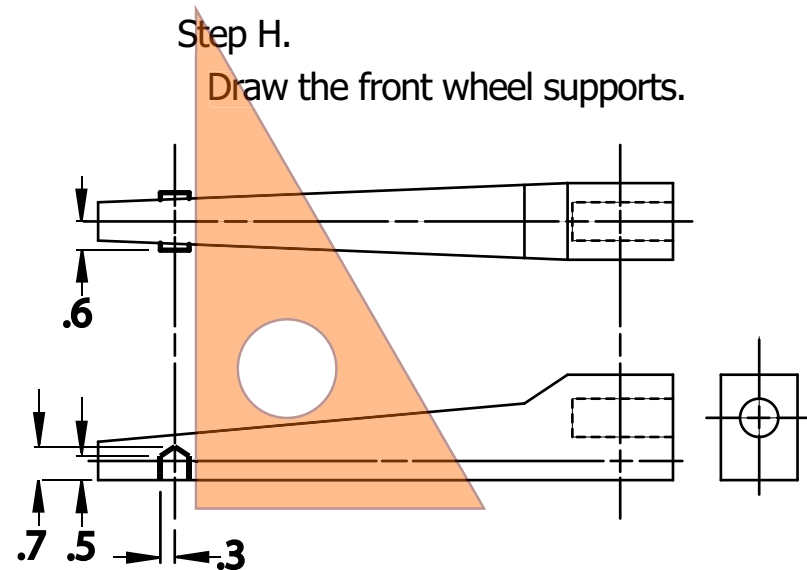

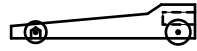

C02 Rail Car Drawing Page 3

Step I.

First, draw wheels using compass. Set compass points to half the diameter. Then, transfer diameter of the wheels to the other views using T-square and triangle.

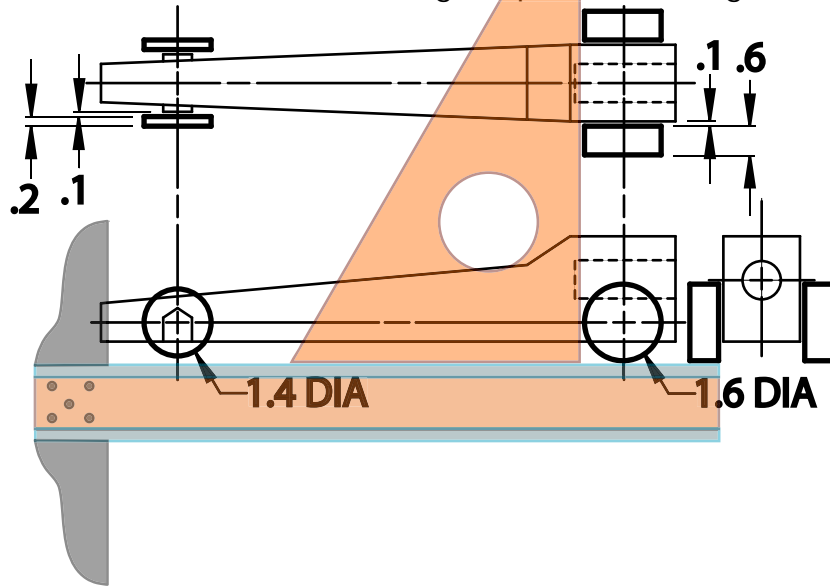

Step J.

First, draw two axles .125 diameter in side view. Use circle template to draw circles. Then, use T-square to transfer axles to back view. Use Triangle to transfer axles to Top View.

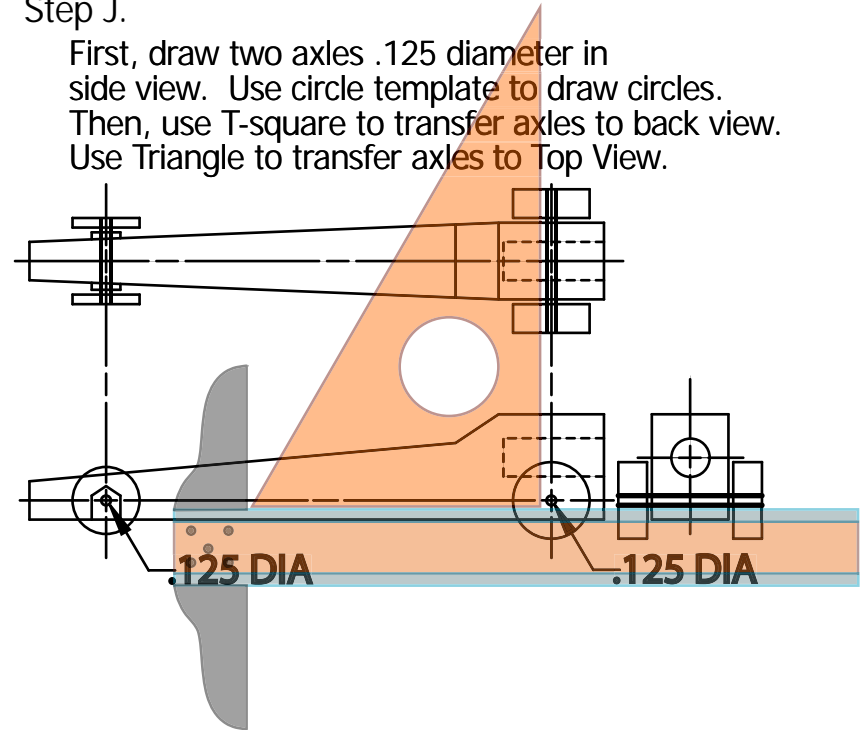

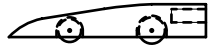

CO2 Shell Car Drawing

Step A.

Draw a LIGHT rectangle around the center of your paper.
Use the overall size of 14.6 by 8

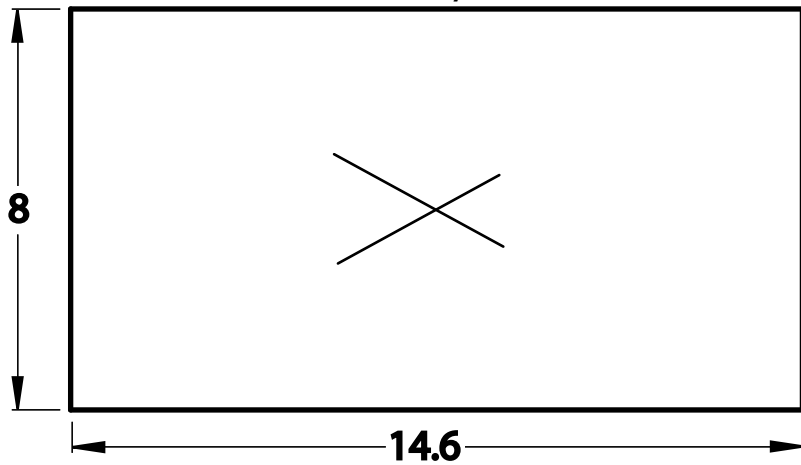

Step B.

Divide the rectangle into four views.
Erase lines between views.

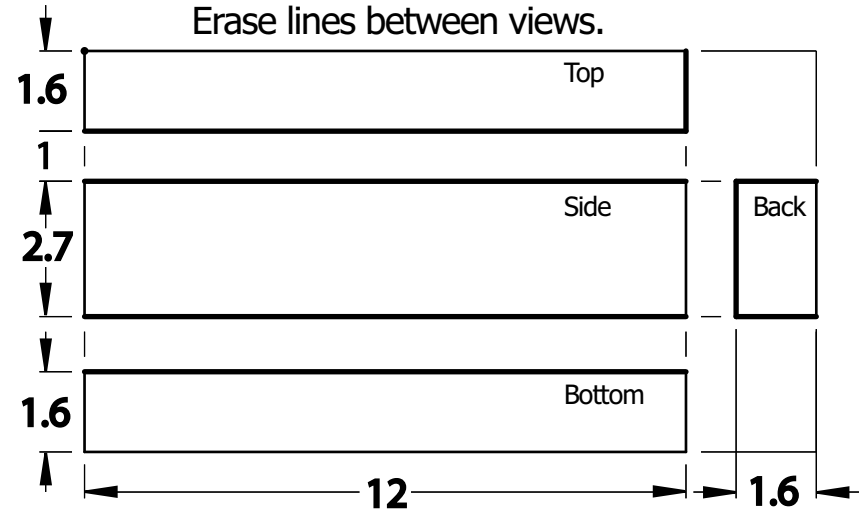

Step C.

Draw line for blank in side view.

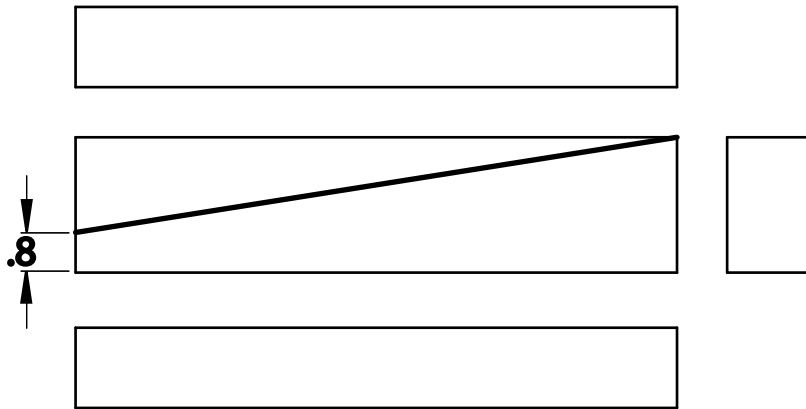

Step D.

Draw center lines to locate cartridge hole. Erase lines.

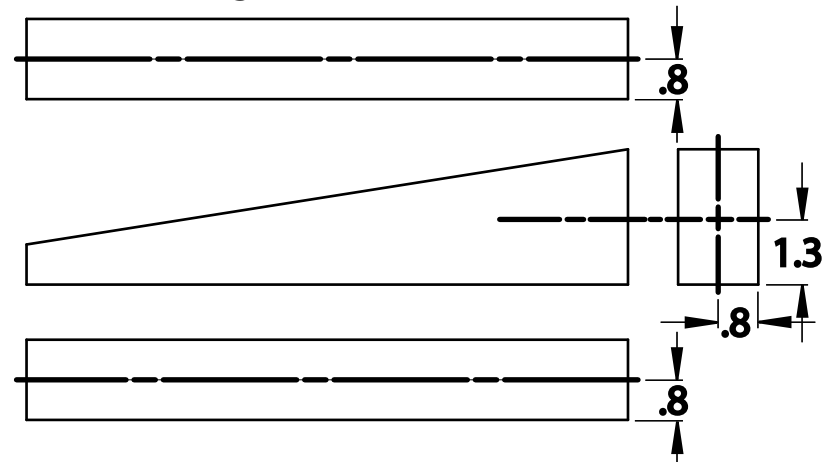

CO2 Shell Car Drawing

Step E.

First, draw cartridge hole .812 diameter in back view. Use circle template to draw circle. Then, use T-square to transfer to side view. Use Triangle to transfer to Top View.

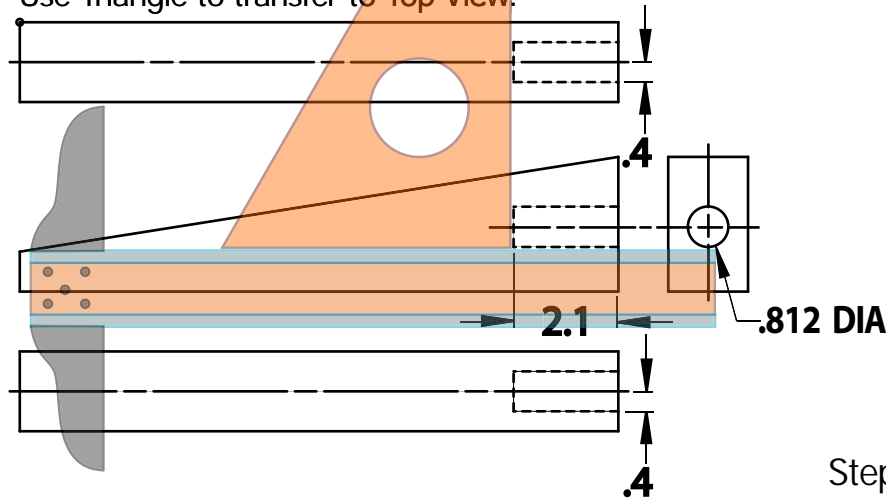

Step F.

Draw the line for the top of the body.

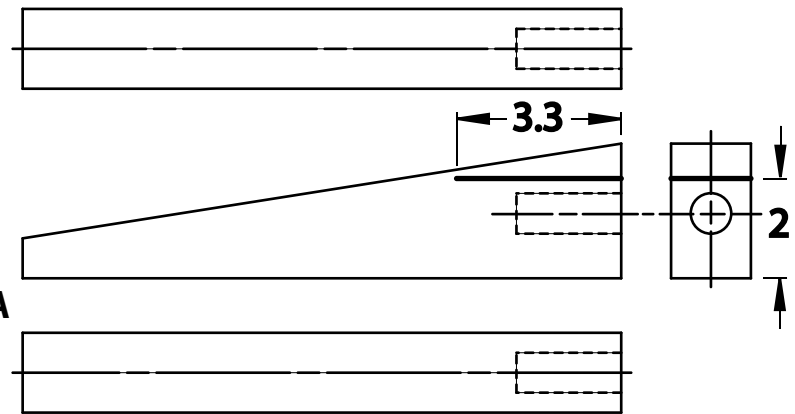

Step G.

Locate points in all view for the body shape.

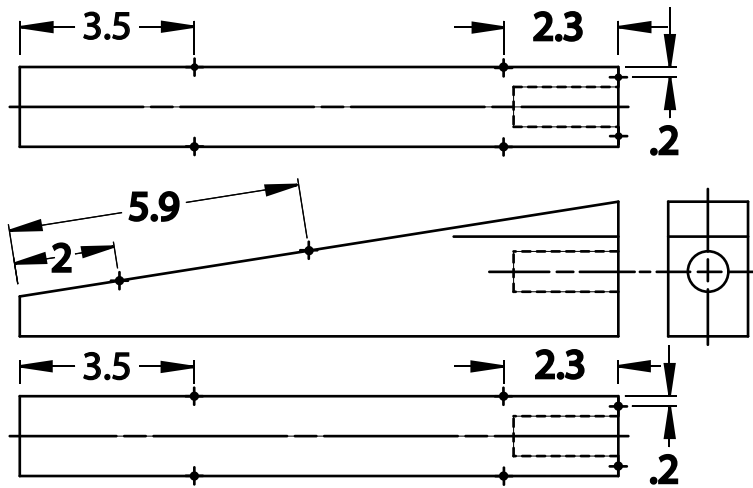

Step H.

Line up the French Curve at two points and draw in a curve. Draw in all the curves. Match up the French Curve with your points to find the right curve.

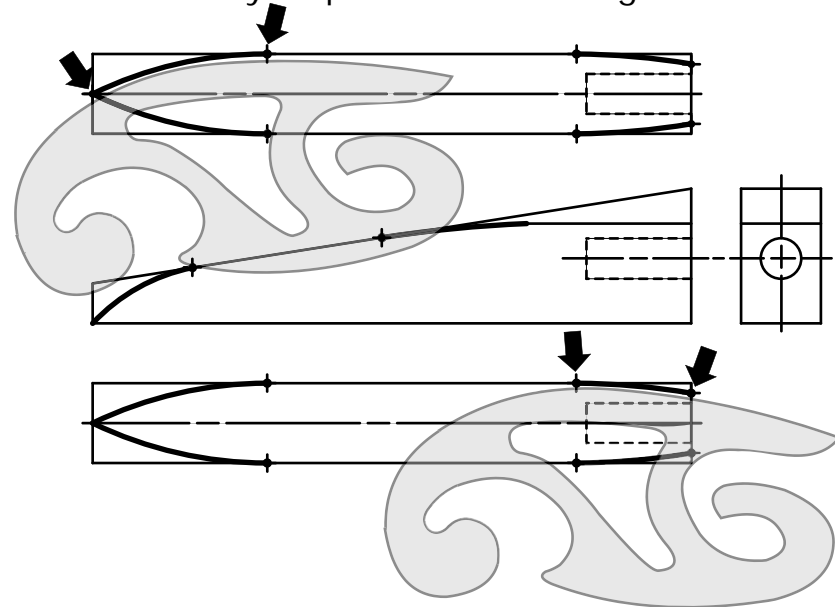

CO2 Shell Car Drawing Page 2

Step E.

First, draw cartridge hole .812 diameter in back view. Use circle template to draw circle. Then, use T-square to transfer to side view. Use Triangle to transfer to Top View.

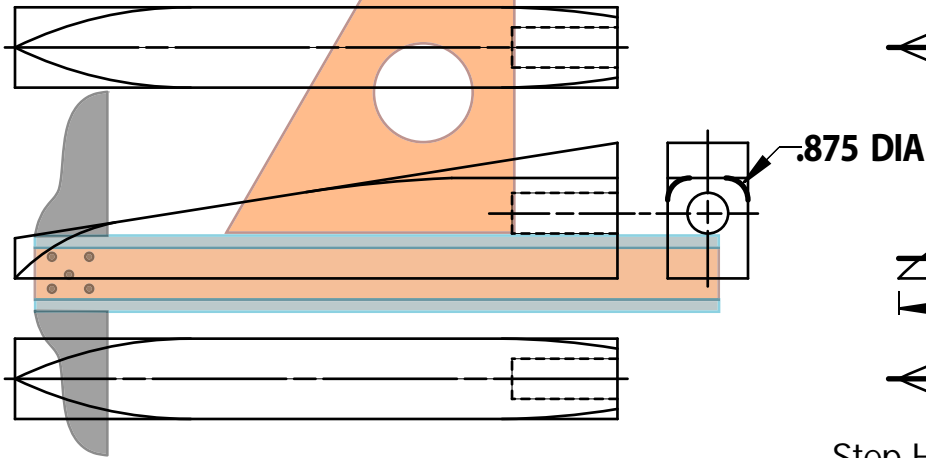

Step F.

Draw the line for the top of the body.

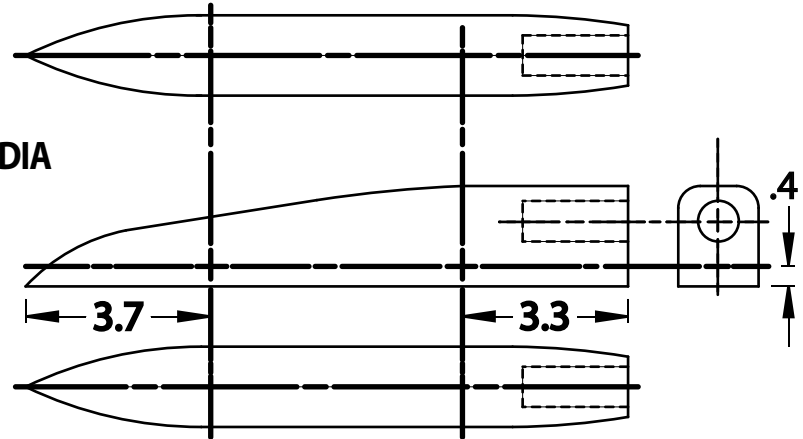

Step G.

Locate points in all view for the body shape.

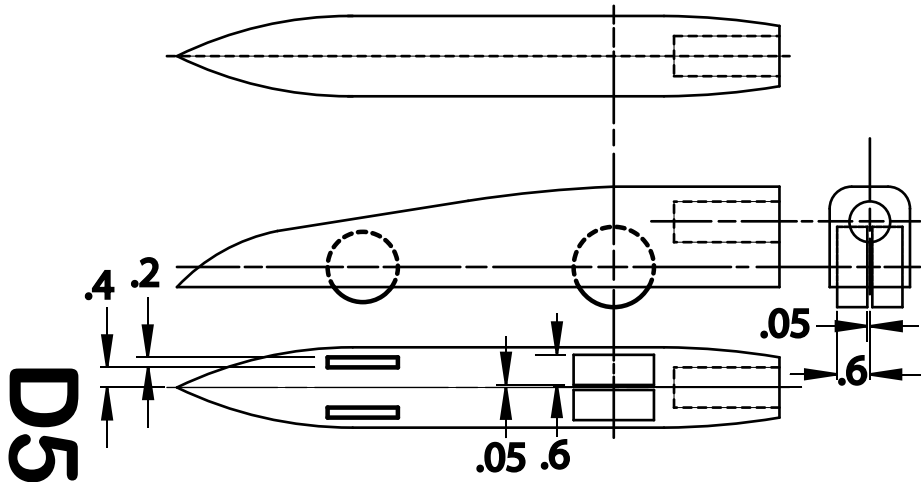

Step H.

Line up the French Curve at two points and draw in a curve. Draw in all the curves. Match up the French Curve with your points to find the right curve.

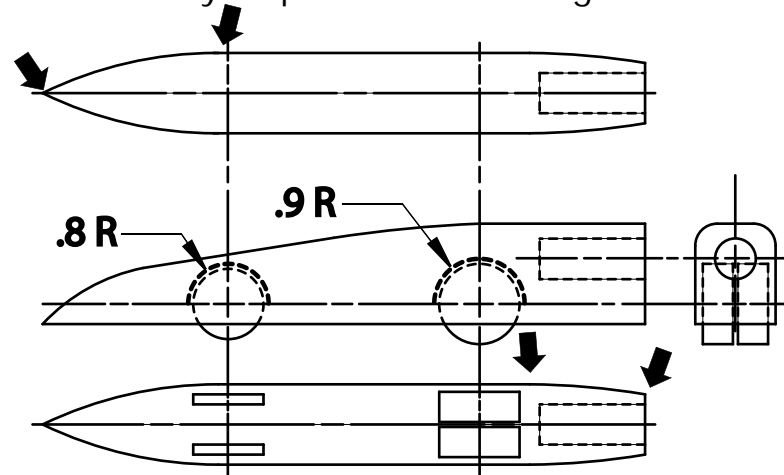

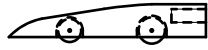

CO2 Shell Car Drawing

Step M.

Draw vertical lines at the ends of shell arcs.
Draw the shells in the bottom view.

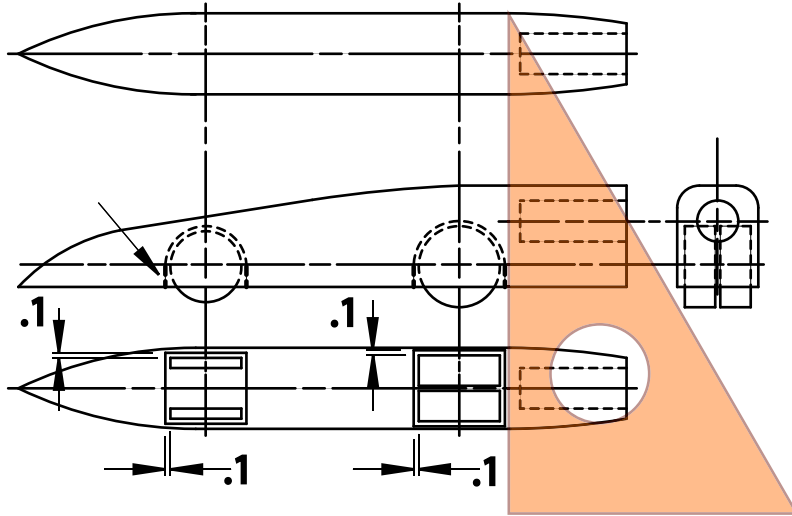

Step N.

First, draw both axles .125 diameter in side view. Use circle template to draw circles. Then, use T-square to transfer axles to back view. Use Triangle to transfer axles to bottom view.

